

PoolShot

Installation and Operating Manual



Always wear personal protective equipment such as gloves and safety glasses when working with potentially hazardous chemicals.



Caution—Refer to accompanying documents.



Caution—Risk of electric shock



Electrical installation of this equipment should only be performed by trained personnel in accordance with local electrical wiring regulations (in North America, refer to NEC and CSA, C22.2 CEC Part 1). Before working with this equipment, isolate it from any electrical source and lock out/tag out.



A circuit breaker must be included in the installation's building. It must be installed in close proximity to the equipment and within easy reach of the operator, and it must be marked as the disconnecting device for the equipment.



Additional documentation for PoolShot units can be found at: <http://www.beta-technology.com>.



If equipment is used in a manner not specified by the manufacturer, the protection provided may be impaired.

INTRODUCTION

The PoolShot is a water-resistant microprocessor controlled chemical injection device for accurate dose delivery upon demand. Features of the PoolShot include:

- Programmable Delay time from 1 to 19 minutes, 59 sec.
- Programmable Dose time from to 19 minutes, 59 sec.
- Programmable Lockout time from 1 to 19 minutes, 59 sec..
- Recycle timer feature: Delay/dose/lockout cycle is performed indefinitely when turned on, instead of just once when the button is pushed.
- Can be run using the recycle timer, or triggered by pushing the dose button, or from an external controller, using either

a contact closure signal or a 24-240 VAC signal and with Opto-Coupler #067480.

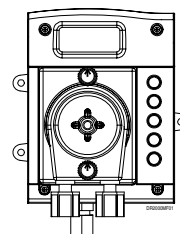

Figure 1a. PoolShot



The PoolShot can also be used as a "slave" pump to an ORP pH controller.

PREFACE

This manual describes how to install, setup, operate and maintain the PoolShot. Material in this manual is subject to change without notice. Manual revisions will be made on an as needed basis. Special circumstances involving important design, operation or application information will be released via Equipment Technical Bulletins.

© Copyright 2009 Beta Technology

SAFETY

These symbols on the unit mean:



SPECIFICATIONS

OPERATING CONDITIONS

Ambient Operating Temperature

5 to 40°C (41 to 104°F)

Electrical Power

115V~ 50/60 Hz 0.1A or 230V~ 50/60 Hz

Voltage fluctuations up to +/- 10% of nominal voltage.

Altitude

Max operating altitude 2000 meters (6500 feet)

Humidity

Max relative humidity 80% for temperatures up to 31°C (87.8°F), decreasing linearly to 50% relative humidity at 40°C (104°F).

Ratings

Pollution Degree: 2

Installation Category II

Intended for indoor or outdoor use (CSA approved for indoor use only).

TIMING CAPABILITY

One Delay event, one Dose event and one Lockout event can be programmed, each with a duration of from 1 second to 19 minutes and 59 seconds. These events will occur in the order Delay, Dose, Lockout each time the dose button is triggered. If the dose button is triggered during a Delay or Dose event the Delay and Dose will be canceled and the PoolShot will go straight to the Lockout event. If the dose button is triggered during a Lockout event it will be ignored.

If the recycle timer feature is turned on, as long as the unit has power it will count down the delay time, pump for the programmed dose time, count down the lockout time, and then recycle or run the cycle again indefinitely, without the need for a trigger or push of the button.

DIMENSIONS

Size	Height	Width*	Depth**
Inches	5.6	4.6	4.8
Centimeters	14.2	11.6	12.2

*Width includes feet.

**Depth with SnapHead pump cartridge in place.

Weight

1.85 lbs/0.84 kg

Volume Per Day Output

Flex Tube, 14 GPD/53 LPD at 30 psi/2.07 bar

**Volume with line-powered dispenser. Flow rates with battery-powered units will vary. If using a battery-powered dispenser, we recommend you test its flow rate under typical operating conditions.*

COMPONENTS

Enclosure

Molded ABS plastic, water-resistant, flame-resistant

Pump

Peristaltic, self-priming and self-checking,
6 Volts DC

Speed & Displacement

100 rpm, 2.5 oz per minute at 30/74 milliliters
30 psi/2.07 bar nominal*

Max duty cycle 19 min. 59 sec ON, 20 min. OFF.

**Actual values may vary depending on operating conditions. We recommend that you test output at startup and at regular intervals for optimum performance.*

Hydraulic Performance

Maximum Vacuum: 12 in of mercury

Maximum Pressure: 30 psi

Tubing Material

Flex

Coin Battery

3 Volt Lithium BR2032 or CR2032 – See **OFF-SEASON STORAGE INSTRUCTIONS—PRESERVING PCB BATTERY LIFE AND PROGRAMMING DATA** in the **MAINTENANCE** section for instructions on preserving battery power and storing the unit during the off-season.

Regulatory

NSF50, CE, CSA (115V only)

INSTALLATION



Refer installation and service to qualified personnel only.

Unplug unit to ensure high voltage is off before servicing.

Installation must comply with all applicable plumbing and electrical codes.

INSTALLING THE TUBING INTO THE PUMP CARTRIDGES

The PoolShot comes with the pump cartridges affixed to it without tubing. Following these instruction for installing the tubing into the pump cartridge.

1. Make sure the PoolShot is powered off.

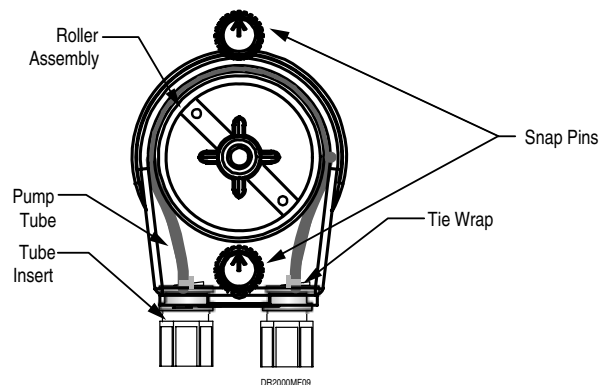

Figure 1b. SnapHead Pump Cartridge

2. Turn the SnapHead pins to the left or right to remove the pump head.
3. Loosen but do not remove the small screw at the bottom of the rear cover and lift the cover from the cartridge.

4. Coat the inside radius of the pump cartridge (the part that comes in contact with the tubing) with Dow Corning III lubricant.
5. Place the squeeze tube inside the pump cartridge.
6. Press the two tube inserts into the cartridge so that the tie wrap "buckles" face toward the center of the pump. **The tube must not be twisted during the assembly.**
7. Replace the rear cover and tighten the scREW.
8. Push the black SnapHead pins back into position, with the arrow pointing up or down.

MOUNTING

The PoolShot should be wall-mounted so the LCD screen can be viewed easily. It should be located immediately above the chemical source, as close to the injection point as possible, usually between the heater and pool/spa.

Mount the unit either by attaching the plastic tabs on the sides of the unit to a wall, or by screwing the bracket into the wall and sliding the PoolShot over it.

INSTALLING SUPPLY LINES

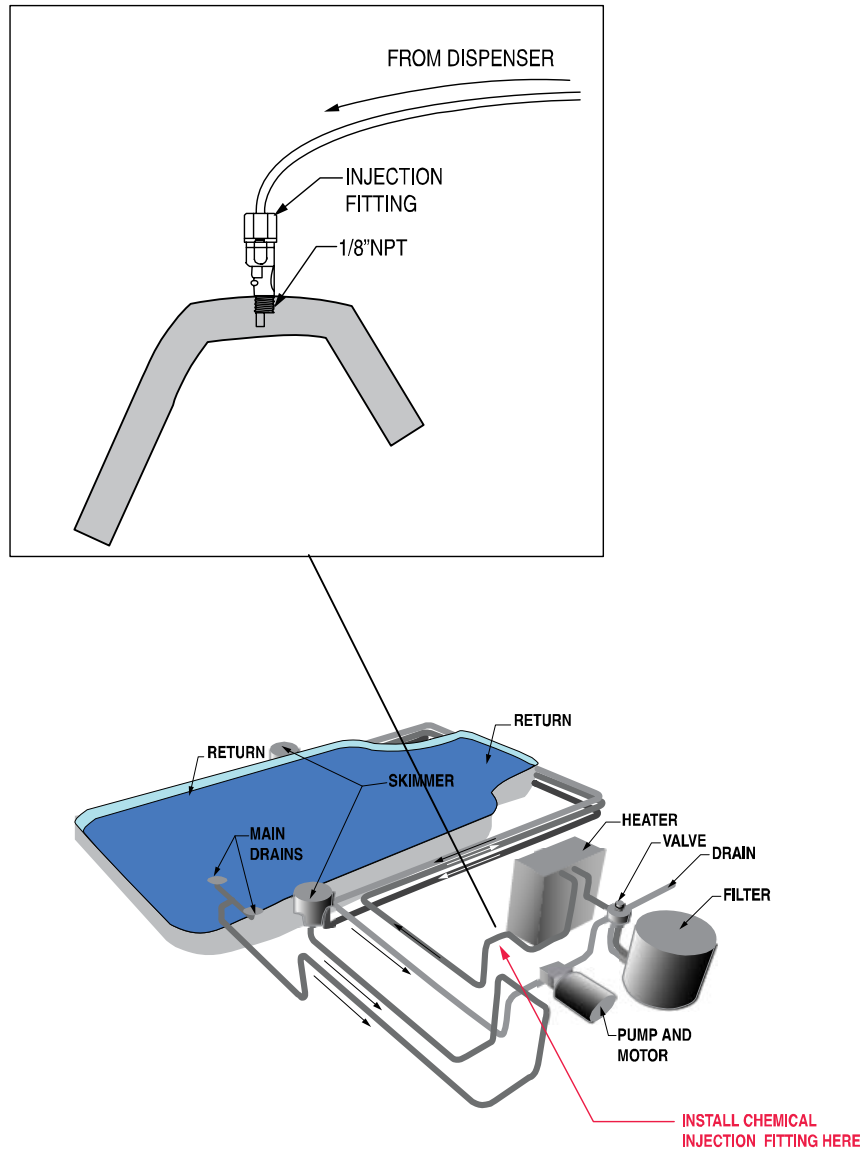

Figure 2. PoolShot Full Installation

1. Cut the desired length of 1/4-inch chemical feed line and attach it to the nut of the left side (suction side) of the pump squeeze tube.



Figure 3. Installing the Chemical Feed Line to the Squeeze Tube Fitting.

2. Cut the bottom of the chemical feed line tubing at a 45-degree angle and press it into the standpipe. Insert the chemical feed line 0.5 inches (12 mm) above the bottom of the standpipe. Both the 45-degree cut and the 0.5-inch (12-mm) distance above the bottom of the standpipe will help avoid the formation of a seal with the bottom of the chemical drum and ensure an unobstructed chemical uptake.

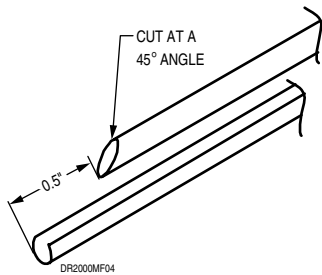

Figure 4. Cutting Chemical Feed Tubing, Inserting into Standpipe

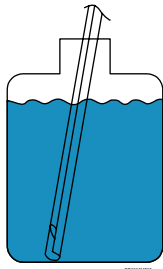

Figure 5. Chemical Feed Tubing (uptake side) with Standpipe in Chemical Drum

- Cut and connect the desired length of chemical feed line for the chemical delivery to the right side of the pump squeeze tube. Run the delivery tube to the desired injection point.
Power Supply

This unit comes with a standard power cord. No ground connection is required.



Dispenser power should be interlocked with circulation power supply.

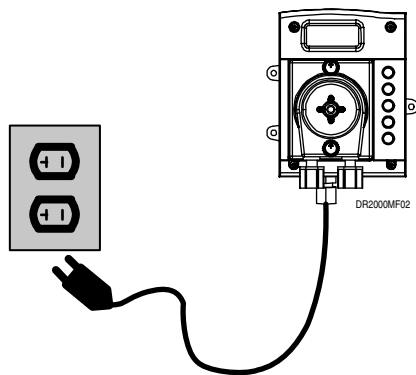

Figure 6. Plugging PoolShot into Outlet

COIN CELL BATTERY SERVICE REQUIREMENTS

If the PoolShot is unplugged for more than 6 months (cumulative) you will need to replace the coin cell battery. You will need to reprogram the PoolShot after replacing this battery.

PRIMING

- Ensure that you are in Run Mode (screen displays “-”).
- Press the Prime button to operate the pump.

Note that once the recycle feature is on, the unit will run as directed by the current run step, but will not respond to the prime button.



There is a 3-volt lithium battery on the main PCB that serves as an emergency backup power supply. This battery provides backup power to retain the settings during power loss. It provides enough power to retain event data but will not run the pump. The life of this battery will depend on the amount of time that power is lost during the lifetime of the pump and the average ambient temperature. Because of the extremely low power demands of the PoolShot, it may never be necessary to change this battery. If this battery does go dead all programmed events will be erased after a power loss. A replacement battery can be purchased commercially. See the Periodic Maintenance section for more information.

SETUP & PROGRAMMING

During normal operation, the PoolShot is in Run Mode. After you have programmed the unit (usually in Recycle Mode) the screen will display which step it's in, 1 for delay, 2 for pump run, 3 for lockout, counting down the time to complete the step and advance to the next step. It will perform this cycle indefinitely, running if it is plugged into power, or just counting through the steps without running if it is not plugged in.

If Recycle Mode is off as it is before programming, in Run Mode the screen will display “-”.

The PoolShot is programmed using the 5-button keypad and display screen in the front of the unit.

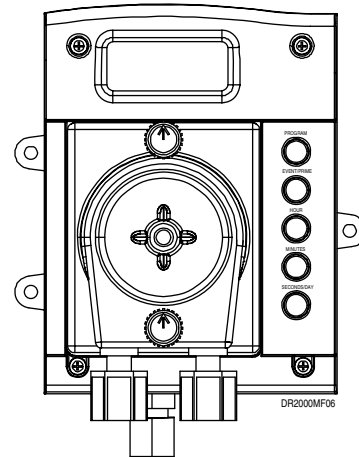

Figure 8. PoolShot, Front Plate

PROGRAMMING

To begin programming, you must first enter into Program Mode. To do this, hold down the Program button for 8 seconds.

A “P” will appear to indicate that you have successfully entered Program Mode. The screen displays a “1” in the upper left to indicate that you are in the Delay Time menu. The screen will display the current Delay Time setting in minutes and seconds and “MIN: SEC” will appear in the lower right of the screen.

1=DELAY TIME

Use the Minutes and Seconds buttons to change the length of the Delay event. The Delay Time can be set for up to 19 minutes and 59 seconds. Setting the Delay Time to 0:00 assures that there will be no delay and when activated the pump will go directly to the Dose event.

Example:

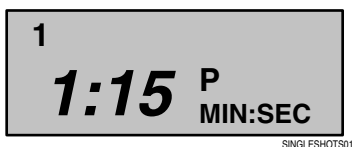

The screen above indicates that you are in Program Mode, in the Delay Time Menu and have a Delay Time set for 1 minute and 15 seconds.

2=PUMP RUN TIME

When you have finished programming the Delay Time, press the event/prime button. A 2 will appear to indicate that you are in the Dose Time menu. The current Dose Run Time will be displayed in minutes and seconds. Use the Minutes and Seconds buttons to set the Dose Run Time. This can be set for up to 19 minutes and 59 seconds.

Once you have entered a run time, you can activate the dose event from this menu for up to the amount of time programmed. This will allow you to confirm the programmed runtime will give you enough chemical, so you can modify it if necessary, without exiting the menu.

To activate the dose event simply push the Dose button from this menu. The display will count up the event and the pump will run for the programmed Dose Run Time. Pushing the button a second time will stop the pump from running.

Example:

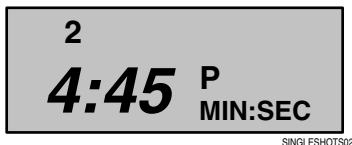

The screen above indicates that you are in Program Mode, in the Dose Run Time Menu, and have a Dose Run Time set for 4 minute and 45 seconds.



The duty cycle for PoolShot should be no more than 19 minutes, 59 seconds on/19 minutes, 59 seconds off.

VOLUMETRIC DOSE RUN TIME SETTING

If desired, you can also set the Dose Run Time volumetrically. To do so you must first program a run time for the dose from the Dose Run Time menu. Choose a run time that you expect to be more than the run time you will need.

In Program Mode, from the Dose Run Time menu, press the Dose button to begin the dose. Measure the chemical delivered. When the desired volume of chemical has been delivered press the dose button again to stop the pump. The time the pump ran will now replace the programmed Dose Run Time.

Example: You want to program a dose of 100 ml. You expect that the pump will need to run for somewhere between 30 seconds and 1 minute in order to pump 100 ml. Remember the flow rate for PoolShot with Flex squeeze tube should be around 150 ml per minute but this may vary depending on chemical viscosity, temperature etc.

From the Dose Run Time menu in Program Mode, set a Dose Run Time of 1 minute (more time than you expect you will need). Without leaving this menu, press the Dose button. Catch the chemical pumped by the PoolShot in a graduated cylinder. When 100 ml of chemical has been delivered press the Dose button again to stop the pump. The programmed Dose Run Time will be replaced with this new value, the actual time it took to deliver 100 ml of chemical (the time between the first time you pressed the Dose button and the second time you pressed it).

3=LOCKOUT TIME

When you have finished with the Dose Run Time, press the Event/Prime button again. A 3 will appear to indicate that you are now in the Lockout Time menu. The current Lockout Time will be displayed in minutes and seconds. Use the Minutes and Seconds buttons to set the desired Lockout Time. This can be set for up to 19 minutes and 59 seconds. A setting of 0:00 will assure that there is no Lockout event.

Example:

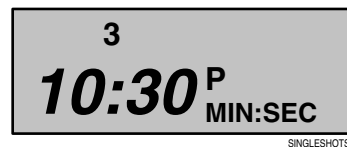

The screen above indicates that you are in Program Mode, in the Lockout Time Menu and have a Lockout Time of 10 minutes and 30 seconds.

4=RECYCLE TIMER FEATURE

The Recycle feature is by default off, with a setting of 0. Press either the Minutes or Seconds button once to change the 0 to a 1, which turns this feature on, such that the pump will continuously run through the Delay/Run/Lockout cycle sequence.

RETURNING TO RUN MODE

When you have finished programming, you can return to Run Mode by pressing the Program button once. The “-” will appear briefly and, assuming the Recycle feature is turned on, the unit will begin counting down the Delay time before proceeding to

Run, Lockout, and repeat. In Run Mode, the “P” will no longer be illuminated. If you leave the PoolShot in Program Mode and unattended for 2 1/2 minutes, it will switch back into Run Mode automatically.

EXTERNAL CONTROLLER TRIGGERING

PoolShot can be plugged directly into an 115VAC outlet on an ORP pH controller. It can then function as a “slave” pump and be programmed with a 10-minute runtime and a 1-second delay.



When using the PoolShot as a “slave” pump with an ORP pH controller, the capacity of the pool being serviced must not exceed 75,000 gallons. You must also replace the backup battery every 12 months.

PoolShot can be triggered by an external controller which can provide a contact closure directly, or a 24-240 VAC signal through an opto-coupler that is applied to the J3 input on the main PCB.

Note that the external controller triggering is not required when operating with the Recycle feature on, as the unit will just trigger itself with a timer. Because this triggering is only used with the Recycle feature off, the unit just performs the programmed dose when triggered by the Dose button or the electric signal from the controller.

Attach contact closure wires or the opto-coupler (#067480) as described below using a strain relief such as #032121.

Removing the Knockout

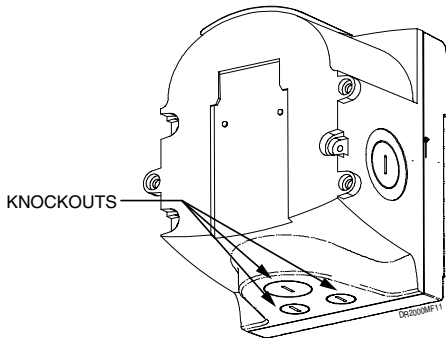

Figure 8a. Bottom of Unit, Knockouts

1. Remove the front plate.
2. Remove the wires from the motor terminals.
3. Remove the motor gearbox from the front plate.
4. Re-mount the front plate without the motor gearbox to add stability to the pump housing while removing the knockout.
5. Insert a screwdriver into the groove in the middle of the “knockout” you have selected. Either the small left or right knockout may be used.
6. Rock the screwdriver back and forth while applying pressure. Work the screwdriver through the plastic.
7. Insert the screwdriver and gently pry up, being careful not to damage the pump housing.

8. Work from the center of the knockout toward one side and then around, gently prying the knockout plastic free.
9. Clear any plastic burrs that remain.
10. Remove the front plate, re-mount the motor gearbox and reconnect wire leads to motor terminals (black wire to terminal with red dot).

Mounting the Strain Relief

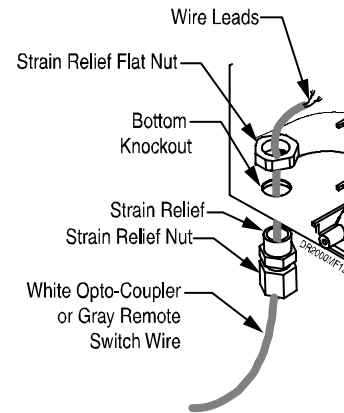

Figure 8b. Mounting Strain Relief

1. Remove flat nut from strain relief.
2. Feed the white opto-coupler wire through the strain relief nut and through the strain relief so that about 2” (5 cm) of the wire stick out from the top of the strain relief.
3. Insert wire and strain relief into the pump enclosure through the bottom knockout as shown in Figure 8b and tighten the strain relief nut.
4. From inside the pump enclosure, feed the end of the wire through the strain relief flat nut.
5. Tighten the flat nut onto the strain relief to hold wire in place and ensure the pump’s water resistance.

Connecting the Wires to the PCB

Opto-Coupler

Attach the wires as per the opto-coupler instructions.



Ensure that the trigger wire voltage and temperature rating are suitable for the application.



Opto-coupler #067480 may trigger with low voltage (such as 3-14V), such that if electrical noise over 3V is present a different opto-coupler should be used.

1. When installing the opto-coupler the white wire goes to the PoolShot and the black lead goes to the pump trigger source.
2. Connect the leads of the white wire (blue and brown) as indicated in the drawing. **The orientation is important.** The blue lead connects to the position closest to the coin cell battery (top) and the brown lead goes to the position closest to J3 (bottom). If these leads are reversed, the opto-coupler will not work and can be damaged. See Figure 8c.

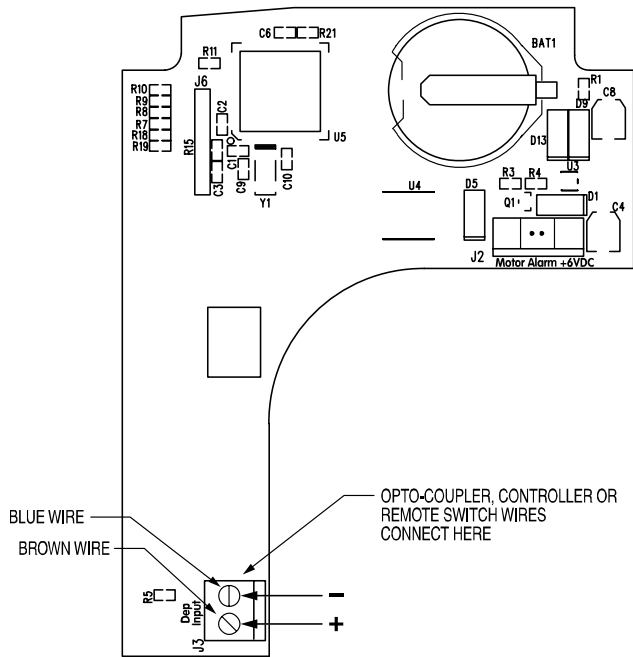

Figure 8c. Connecting Contact Closure Signal or Opto-Coupler

Contact Closure Signal

The J3 terminal can also be used to connect a remote switch (for remote push-button dose activation) or relay contacts (like from a controller).

The polarity does not matter for this application. Simply connect the lead wires to the terminals on J3 as shown in Figure 8c.

Reassembling the Pump

Re-mount the pump front plate with the motor gearbox. Be sure that the wire leads are connected to the motor terminal (black wire to terminal with red dot).

USING THE POOLSHOT

When the PoolShot receives a signal from pressing the Dose button, remote switch or closed-contact signal (opto-coupler), it will activate a dose event.

The Screen will display a 1 to indicate that it is in a Delay event, and countdown the Delay Time. When the Delay event ends the screen will display a 2 to indicate that it is in a Dose event, the Dose Run Time will begin counting down and the pump will activate. When the Dose ends, the screen will change to display a 3 to indicate that it is in a Lockout event and the screen will count down the Lockout Time. When the Lockout ends the pump will return to Run Mode and “-” will be displayed.

If no delay is programmed, the PoolShot will go straight to the Dose Event when the dose button is pressed. If no Lockout is programmed, the pump will go straight back to Run Mode when the Dose Event ends.

If a signal is received and a dose is activated by mistake, pressing the Dose button or sending a second signal will cancel the event and take the PoolShot directly to the Lockout Event. **This means that if the PoolShot receives a signal during a**

Dose event, the Dose event will be cancelled before it is completed.

MAINTENANCE



Disconnect power from dispenser before performing any maintenance.



Safety glasses and protective clothing should be worn while servicing the PoolShot.



Refer installation and service to qualified personnel only.

OFF-SEASON STORAGE INSTRUCTIONS—PRESERVING PCB BATTERY LIFE AND PROGRAMMING DATA

The dispenser’s PCB battery normally lasts about 10 years with continuous use. However, there may be times, like during the off-season, when your dispenser will be stored and left unused for months at a time. When the dispenser is unplugged and drawing backup power, the battery life is only about 6 months, and once the battery runs out, all programming is lost.

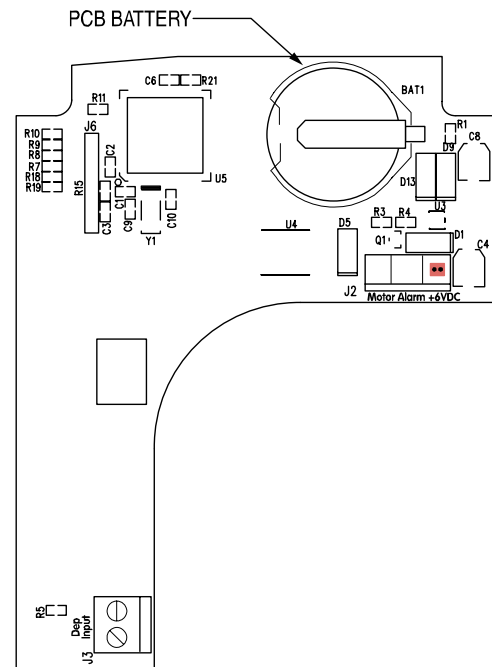

Figure 8.1. PoolShot Main PCB

Follow these steps to ensure maximum battery life and to retain programming data:

- If possible, store the dispenser plugged in. This will preserve its programming and preserve the life of the backup battery.

- If #1 cannot be done follow these steps:
 1. Store the dispenser for no more than 6 months. At startup of the new season, verify unit still has a working display. If so, plug unit into power source for 15-20 seconds. This will charge the capacitor on PCB.
 2. Remove the 4 screws on the front of the dispenser to access its PCB, but do not remove the harness between the PCBs.

IMPORTANT: YOU MUST REPLACE THE OLD BATTERY WITH THE NEW ONE WITHIN 15 SECONDS OF REMOVING OLD BATTERY IN ORDER TO RETAIN PROGRAMMING.
 3. Remove battery from battery holder on main PCB (needle-nose pliers may help).
 4. Replace battery with Beta item # 058942 **within 15 seconds of removal**. Reassemble. Programmed data should be intact.

PERIODIC MAINTENANCE

Pump & Squeeze Tube Replacement Schedule

Since every installation is different (chemicals, tube runs, operating frequency, and so on), an exact tube replacement schedule cannot be specified. With use, the tube slowly evolves from round to oval and the amount of chemical pumped decreases. By regularly checking the amount of chemical pumped, you can determine general tube life. It is recommended that you closely monitor the time it takes the original tube to reach the end of its flex life, and then establish a replacement schedule. Replacing tubes at regularly scheduled intervals ensures more accurate product use and reduces service calls. In general, short feed lines of a large diameter will improve pump tube life.

REPLACING PUMP CARTRIDGES

To Remove

9. Turn off power to the unit to ensure that the pump does not run during maintenance.

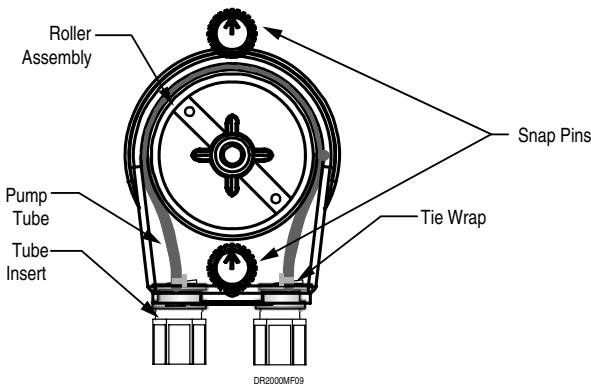

Figure 9. SnapHead Pump Cartridge

10. Turn the SnapHead pins to the left or right to remove the pump head.

11. Remove the supply and feed lines from the old pump squeeze tubing and connect them to the new pump squeeze tubing.

To Install

1. Align and engage the pump drive spline with the motor gear by rotating the roller assembly.
2. **Turn the snap pins so that the arrow is pointed either straight up or down.** Then push in until you hear a distinct click.

Replacing Pump Squeeze Tubing



Disconnect power from circulation system before replacing tubing.



Splash danger! Because the squeeze tube contains chemical product and is flexible, extra caution should be taken while changing the squeeze tube to insure that the chemical does not splash in the eyes or on the hands or clothing of the service person.



Always wear protective eyewear, gloves and protective clothing when changing the squeeze tube.

1. Remove the cartridge as described above.
2. Loosen but do not remove the small screw at the bottom of the rear cover and lift the cover from the cartridge.
3. Pull the roller assembly out of the pump cartridge to release the pump squeeze tubing.
4. Pull the tube inserts out of the pump cartridge.
5. Remove the squeeze tube.
6. Coat the inside radius of the pump cartridge (the part that comes in contact with the tubing) with Dow Corning III lubricant.
7. Replace it with a new squeeze tube.
8. Press the two tube inserts into the cartridge so that the tie wrap "buckles" face toward the center of the pump. Remember, the tube must not be twisted during the assembly.
9. Replace the roller assembly.
10. Replace the rear cover.
11. Push the black SnapHead pins back into position, with the arrow pointing up or down. Re-tighten the screw.

How To Replace Pump Motor

To Remove

1. Ensure that power is off.
2. Remove the 4 screws holding the front plate (bezel) in place.
3. Remove the front plate.
4. Remove the pump cartridge from the motor assembly, leaving the chemical lines attached.

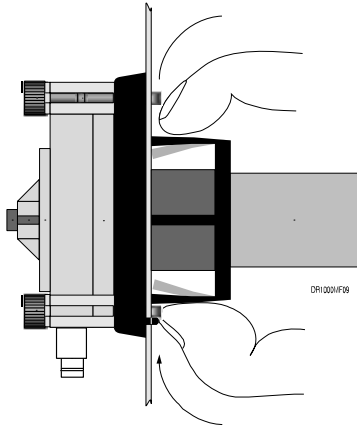

5. Remove the electrical connections at the back of the motor.
6. Compress the two flex ears on the back of the motor until the motor slides out through the hole in the front plate.

To Replace

1. Locate the alignment tip of the motor housing so it is in the down position.
2. Slide the pump motor housing into the front plate hole. The holding ears will expand to hold the pump motor in place. Verify that both ears popped out and are locked in place.
3. Reinstall the electrical connections at the back of the motor.
4. Install the pump cartridge.
5. Prime the pump to verify proper pump rotation (clockwise). If the direction is wrong, switch the motor wires.

How to Replace the Main PCB

1. Disconnect power to the unit.
2. Remove the 4 screws holding the front plate of the PoolShot control box in place. Remove the front plate (bezel), being careful not to damage the gasket.
3. Detach the power wire connection coming from the power PCB to the main PCB.
4. Detach the motor supply wires from the PCB.
5. Place the bezel face down on the work surface.
6. Remove the 4 screws holding the main PCB to the bezel.
7. Gently lift the main PCB out of the bezel.
8. If the zebra strips and display screen stick to the old PCB, remove them and place them in the bezel, being careful to keep their orientation.
9. Align the new PCB over the zebra strips and replace the 4 screws. Be sure to tighten the screws into position. The pressure these screws exert on the PCB is important for maintaining water resistance and holding the display in place.
10. Reattach the motor supply wires to the main PCB at the terminal marked "motor".
11. Reattach the power supply to the terminal marked "+6VDC".

12. Remount the front plate (bezel) and retighten the screws, being careful not to damage the gasket.



Between the main PCB and the front plate (bezel) are the buttons, screen and zebra strips. It is important that these items are properly aligned and that the screws holding the PCB in place be properly tightened. If these items are not properly aligned and held in place by pressure from the 4 screws, water resistance may be lost around the buttons or the screen may not display properly.

How to Replace the Power PCB

1. Disconnect power to the unit.
2. Remove the 4 screws holding the front plate of the PoolShot control box in place. Remove the front plate (bezel), being careful not to damage the gasket.
3. Detach the power wire connection from the main PCB.
4. Detach the power cord.
5. Remove the screws holding the power PCB in place.
6. Gently lift out the power PCB.
7. Align the new power PCB and replace the screws. Be sure to tighten the screws into position.
8. Reattach the power cord to the terminal block.
9. Reattach the power wire connection from the main PCB.
10. Remount the front plate (bezel) and retighten the screws, being careful not to damage the gasket.

How to Replace Coin Battery

1. Ensure that power is off.
2. Remove the 4 screws holding the front plate of the PoolShot control box in place. Remove the front plate (bezel), being careful not to damage the gasket.
3. Locate the coin battery on the PCB.
4. Slip the coin battery out and replace it with a new one (3 Volt lithium BR2032 or CR2032).
5. Remount the front plate (bezel) and retighten the screws, being careful not to damage the gasket.



When the lithium backup battery is removed, all programmed events will be erased and will need to be reprogrammed.

Cleaning the Unit

Wipe pump housing clean with a dry rag.

TROUBLESHOOTING

Pump Runs Continuously

If the pump runs without being activated, replace the Coin Cell Battery. If the pump continues to run replace the PCB.

Pump is Running Backwards

Check that the polarity of the wires from the main PCB to the motor is correct.

Pump Runs Too Slowly

1. Check that the squeeze tube or pump cartridge is not jammed.
2. Check the chemical uptake line for kinks.
3. Verify that the chemical uptake line is not forming a seal against the side or bottom of the chemical drum (See: **INSTALLING SUPPLY LINES** in **INSTALLATION** section).
4. If the liquid being pumped is very viscous the pump may labor in order to move it. Using a less viscous chemical, pumping shorter distances, setting longer run times, and assuring that the squeeze tube is in good condition will help address this issue.

Also:

1. Verify that the correct line power is installed and adequate power is arriving to the unit.
2. Check for 6.0 volts DC or greater at the motor connection wires with the motor disconnected and the pump prime button activated. If this voltage is present, replace the motor gearbox. If the problem persists after the motor gearbox has been replaced, replace the power PCB. If the voltage is absent replace the main PCB..

Pump Will Not Run

1. Check that the squeeze tube or pump cartridge is not jammed.
2. Check the chemical uptake line for kinks.
3. Verify that the chemical uptake line is not forming a seal against the side or bottom of the chemical drum (See: **INSTALLING SUPPLY LINES** in **INSTALLATION** section).
4. Check to see that the motor connection wires are properly connected from the main PCB to the motor gearbox.
5. Push the Prime button and try to prime the pump. If the pump does prime, check that events are properly programmed.

Also:

1. Verify that the power is connected.
2. Check for 6 to 11 volts in the wire harness from the power PCB to the main PCB. If the voltage is absent replace the power PCB.
3. Check for 6 volts DC or greater at the motor connection wires with the motor disconnected and the pump prime button activated. If this voltage is present, replace the motor gearbox. If the voltage is absent, replace the main PCB.

Events are Erased When Unplugged or Power is Lost

Replace backup battery on the main PCB (see **HOW TO REPLACE THE COIN BATTERY** in the **MAINTENANCE** section of this manual).

Pump Will Not Pull Liquid from the Supply Container

1. If there is too much vacuum created, the pump will not be able to move the chemical. This is easily recognized when the squeeze tubing collapses. If this happens:
 - a) Check that the squeeze tube or pump cartridge is not jammed.
 - b) Check the chemical uptake lines for kinks.
 - c) Ensure that the chemical uptake line is not forming a seal against the side or bottom of the chemical drum (See **INSTALLING SUPPLY LINES** in **INSTALLATION** section).
 - d) Using a less viscous chemical, pumping shorter distances, setting longer run times and ensuring that the squeeze tube is in good condition will help address the issue.
2. Check to see that there is not an air leak somewhere along the chemical supply line.

Intermittent dosing with opto-coupler

Opto-coupler #067480 will trigger at low voltages (of 3-14V). If intermittent triggering occurs, switch trigger source or use with higher-voltage opto-coupler.

SPARE PARTS

Item #	Description
1203652	Flex tube, 0.125 ID
1206740	Pump cartridge without tube
058942	Main PCB battery
093288	Dow Corning III lubricant
1202397	PCB, Main
1202396	PCB, Power 115V
057755	Motor/Gearbox 6V
058942	Coin-Cell Battery, PCB

PRODUCT REPAIR

If an item is in need of repair, please call or write to obtain a Return Authorization (RA) number. Call Customer Service at 1-800-858-2382 (within the U.S.A) or 831-426-0882. They provide RA numbers. Then, please write the number on the outside of the box before sending. It is very helpful to our Repair Department to include a note explaining the nature of the problem. Failure to obtain an authorization number before returning an item may delay repair of the equipment.

APPENDIX/DRAWING LIBRARY

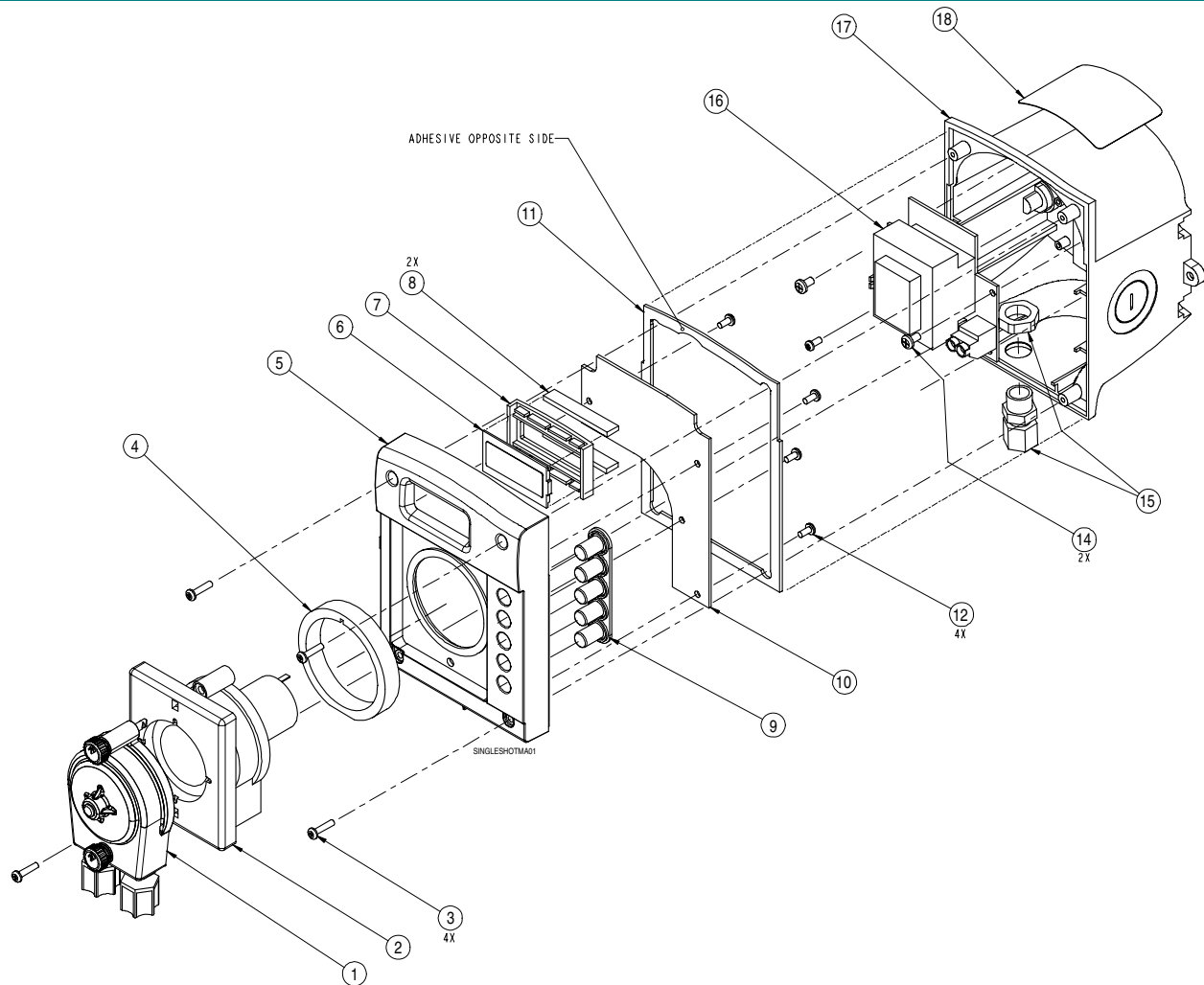

Seq#	Description	Code #	Seq#	Description	Code #
1	SnapHead Pump Cartridge w/Flex Tube	091940	8	Zebra Strips	N/A
2	Pump Motor Gearbox 6 VDC	1207594	9	Buttons	N/A
3	M3 x 12 mm Panhead Bezel Screws	N/A	10	Main PCB	
4	Pump Gasket	099705	11	Bezel Gasket	1202615
5	Main Bezel	N/A	12	Main PCB Screws	N/A
6	LCD	N/A	14	Power PCB Screws	N/A
7	Bracket	N/A	15	Strain Relief	N/A
			16	Power PCB 115 VAC	1202396
				Power PCB 230 VAC	1202678
			17	Bucket	N/A
			18	Serial Label	N/A



Customer Service
 TEL: 831 • 426 • 0882
 TEL: 800 • 858 • 2382 (toll-free in U.S.A.)
 FAX: 831 • 423 • 4573
 FAX: 800 • 221 • 8416
<http://www.beta-technology.com>

Global Technical Customer Service
North America:
 TEL: 800 • 468 • 4893 (toll-free in U.S.A.)
 TEL: 262 • 631 • 4461 (international)
Europe, Middle East & Africa:
 TEL: +1 630 • 513 • 9799

Asia Pacific:
 TEL: +1 86 21-50509900 x 2520
Japan:
 TEL: +1 090-6506-5140
Latin America
 TEL: +1 -541148428270

Beta Technology is ISO9001 Certified